



The AERA Technical Committee offers the following information regarding timing belt installation procedures on 1994-2001 Acura B18 Series engines. Failure to follow these procedures could result in engine damage.

- 1) Position the crankshaft and the camshaft pulleys as shown in Figure 1 before installing the timing belt.
 - a. Set the crankshaft so that the No.1 piston is at top dead center (TDC). Align the groove on the teeth side of the timing belt drive pulley to the ("arrow mark") pointer on the oil pump.
 - b. Align the TDC marks on intake and exhaust pulleys.
- 2) NOTE: To set the camshafts at TDC position for No. 1 piston, align the holes in the camshafts with the holes in No. 1 camshaft holders and insert 5.0 mm pin punches in the holes.
- 3) Install the timing belt tightly in the sequence shown in Figure 2.
 1. Timing belt drive pulley (crankshaft)
 2. Adjusting pulley
 3. Water pump pulley
 4. Exhaust camshaft pulley
 5. Intake camshaft pulley
- 4) Loosen and retighten the adjusting bolt to tension the belt.
- 5) Remove the pin punches
- 6) Rotate the crankshaft about 4 or 6 turns counterclockwise so that the belt positions on the pulleys.
- 7) Adjust the timing belt tension.
- 8) Check the crankshaft pulley and the camshaft pulleys at TDC. They should line up as shown in Figure 3.
- 9) If a camshaft pulley is not positioned at TDC, remove the timing belt and adjust the positioning, then reinstall the timing belt.

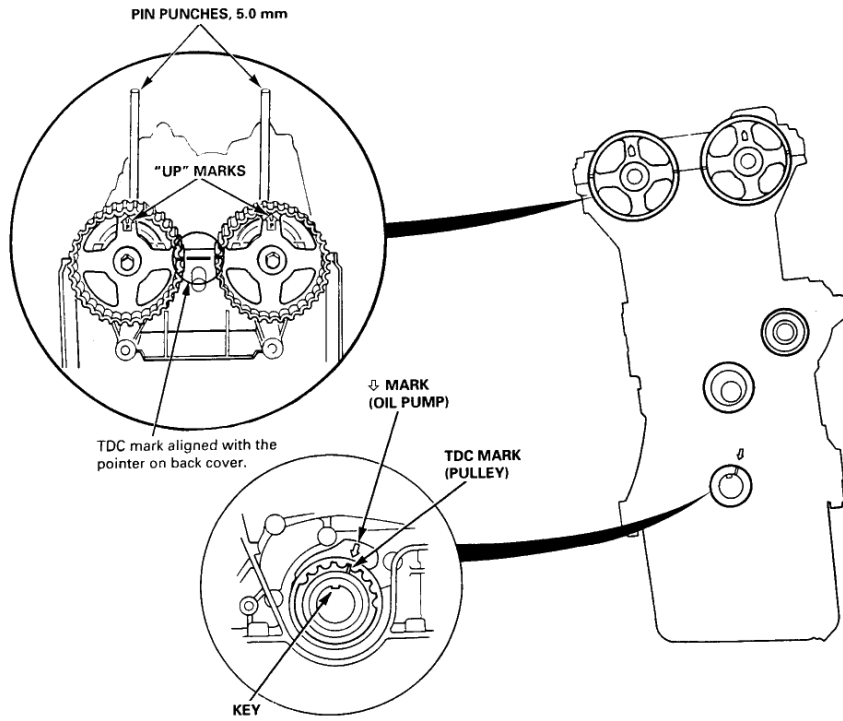

Figure 1: Camshaft & Crankshaft Timing Marks

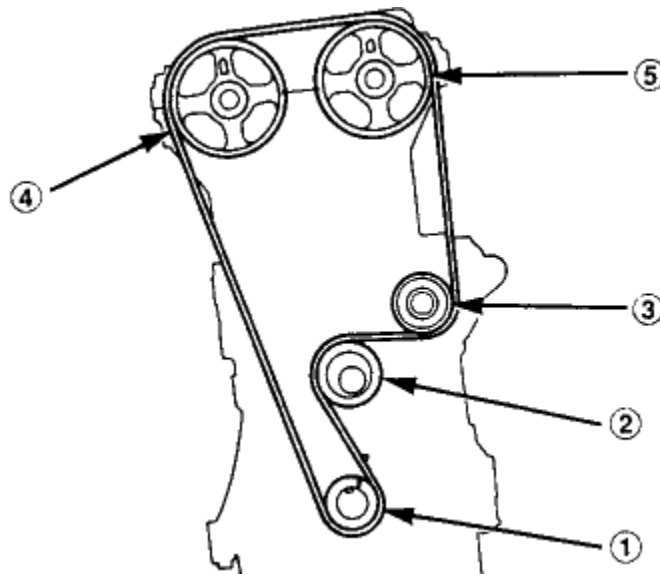

Figure 2: Timing Belt Position

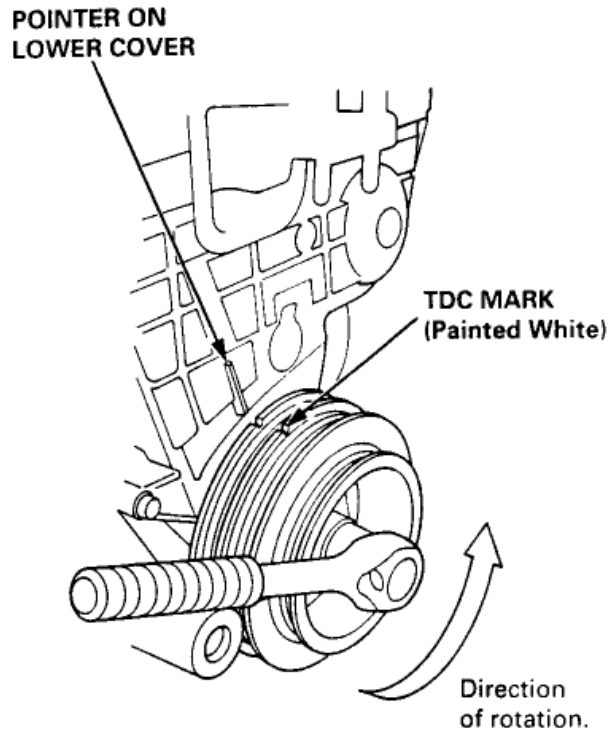

Figure 3: Setting Crankshaft @ TDC

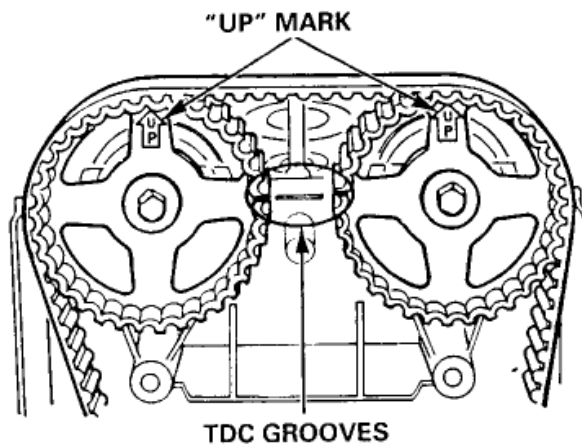

Figure 4: Camshaft Sprocket Timing Marks

The AERA Technical Committee

This information is provided from the best available sources. However, AERA does not assume any responsibility for data accuracy or consequences of its application. Members and others are not authorized to reproduce or distribute this material in any form, or issue it to their branches, divisions or subsidiaries, etc. at a different location without written permission.